

## PANEL INSTALLATION GUIDE

### 1. Introduction

Before starting the installation of sandwich panels it is important to prepare the full cladding design. Such a design should contain the panel cutting list with associated accessories and tools required to complete the installation. Additionally it should contain the installation details for all junctions characteristic for the building in question.

### 2. Support construction geometry

**a.** Before starting the installation of sandwich panels it is important to check the support construction geometry intended to provide support to the cladding system. Installation tolerance should not exceed values described in relevant national standard (for Poland, PN-B-06200:2002/Ap1:2005 „Konstrukcje stalowe budowlane. Warunki wykonania i odbioru. Wymagania podstawowe”)

**b.** Roof pitch is determined by the roof supporting construction and cannot be smaller than:

5% ( $\alpha=2.86^\circ$ ) – for continuous panels without end lap joints along the length of the panel and for roof slopes without rooflights.

7% ( $\alpha=4.00^\circ$ ) - for panels with end lap joints along the length of the panel and for roof slopes with rooflights.

**c.** The distance between supports should be in accordance with the cladding design and in accordance with the load span tables.

**d.** The surface of contact between sandwich panels and support construction should be in a single plane

**e.** The amount of space for free and allowable deflection should be equal for all panels. This is particularly important for panels covering large spans between supports where as a result of uneven deflection the panel joints can open up and leak along the long edge of the panel.

*In case of irregularities in the support construction geometry, it is important to notify the investor or principal contractor immediately about it.*

### 3. General installation guidelines

**a.** Wall sandwich panels are stored in packs in a way that the external face of the panel (external elevation side) is a face down.

**b.** The external face of wall sandwich panels is marked with arrows and text printed on the panel side joint:

**STRONA ZEWNĘTRZNA / OUTSIDE / AUSSENSEITE/  
НАРУЖНАЯ СТОРОНА**

**c.** Protective foil on the panel internal face needs to be removed before the panel installation, while on the external face after the panel installation not later than two months after the panels have been manufactured

**d.** In the case of roof panels with end laps, it is important to remove any insulation residue from the entire depth of the panel cut back

**e.** Before starting the panel installation it is permissible to apply single-sided tape to support construction to avoid scratching the internal face of the panel

**f.** Panel installation should not take place:

- during precipitation

- when wind speeds exceed 7 m/s

- during poor visibility conditions (dusk, thick fog)

**g.** During the installation of the sandwich panels it is imperative to follow the health and safety rules, in particular:

- use safety nets during the installation of roof sandwich panels

- use scaffolding with nets catching any falling objects at the bottom of the elevation and gable walls

- use scaffolding or mobile elevated platforms during the installation of wall sandwich panels

**h.** In the case of internal sandwich panels, due to the possible slight colour difference between the internal and external face of the panel, it is not recommended to meet the internal and external face of panel on a single installation plane.

**NOTE:** Wall sandwich panels with dark colour faces, due to the higher thermal stresses and related possible deformations to the external face, are recommended to be designed as single-spanning panels with a shortened distance between supports. We are recommending to consult Izopanel's technical team on each occasion of using sandwich panels with dark colour faces. Otherwise, Izopanel will not be held liable for any possible damages related to the improper use of sandwich panels.

### 4. Sequence and direction of panel installation

**a.** Installation of roof sandwich panels should begin from a roof edge and should be continued in the direction opposite to prevailing winds. Such arrangement of panels provides additional protection against penetration of wind-driven rain into panel joints (Fig.1)

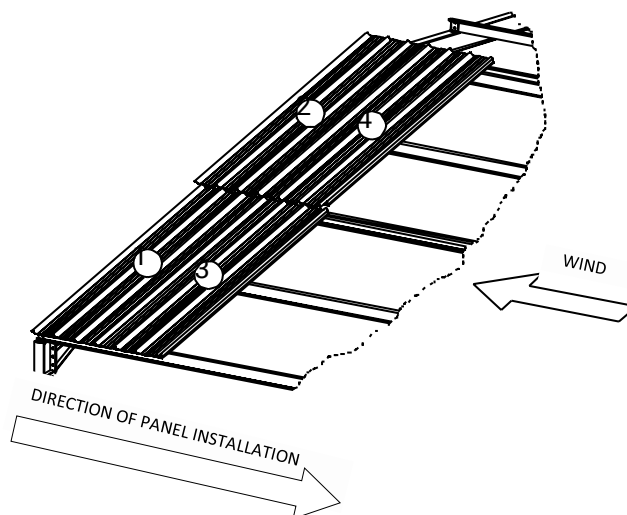

fig.1

**b.** Longitudinal side joints of roof panels on roof slopes of  $5\% \leq a \leq 8\%$  should be sealed with a self-adhesive tape or butyl sealant (Fig.2).

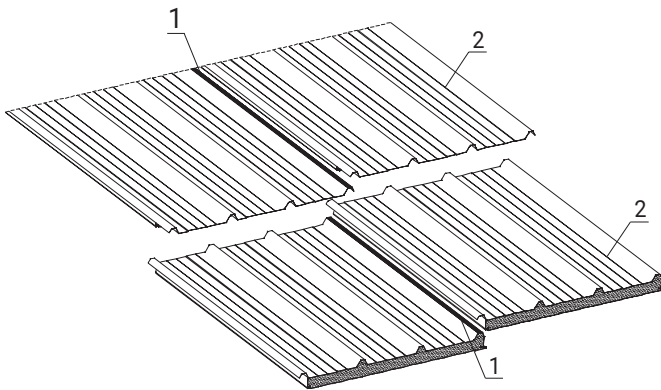

fig. 2

1. Self-adhesive tape or butyl sealant
2. IzoRoof roof sandwich panel

**c.** The end lap joint of roof sandwich panels joined in length should be sealed using two runs of self-adhesive tape or butyl sealant (Fig.3).

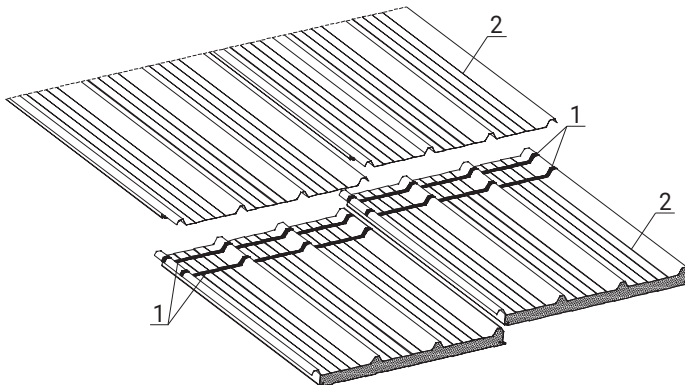

fig. 3

1. Self-adhesive tape or butyl sealant
2. IzoRoof roof sandwich panel

**d.** In the case of roof panels with end laps, the insulation should be cut back by:  $200\text{ mm} < p < 300\text{ mm}$  (Fig.4, p - cut back width).

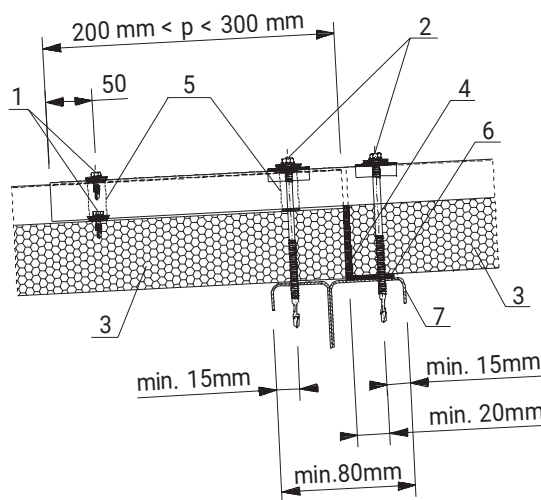

fig. 4

1. Self-drilling fastener with EPDM washer
2. Saddle with a neoprene washer + self-drilling fastener with EPDM washer
3. IzoRoof roof sandwich panel
4. Impregnated gasket or canister applied insulation foam
5. Self-adhesive sealing tape or butyl sealant
6. Spacer tape 3mm thick and a minimum of 40mm wide
7. Support construction.

**e.** Installation of horizontal wall panels should begin from the bottom edge of the building and continue up in the eaves direction.

**f.** Installation of vertical wall panels should begin from the vertical edge of the building and be continued in the direction opposite to prevailing winds.

**g.** Pay adequate attention to sufficiently tighten up the joint between panels, which is essential in achieving a tight joint.

**h.** During the panel installation, it is important to monitor at all times that the panels are installed at right angles to each other and to support construction.

### 5. Panel installation guidelines

**a.** Sandwich panels should be fixed to the supporting construction using fasteners recommended by Izopanel

**b.** Pay adequate attention to correct tightening of fasteners (fig.5)

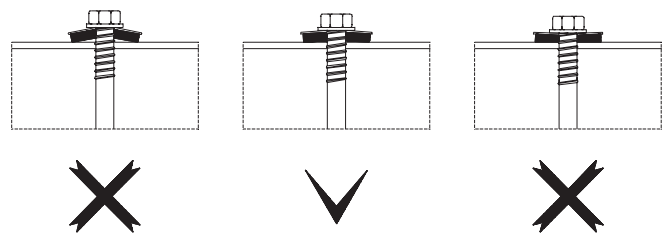

fig. 5

**c.** IzoRoof roof sandwich panels should be fixed only through the raised profile using saddle washer recommended by Izopanel (Fig.6). Fixing the roof panels to support construction between the raised profiles (in large valleys where the rainwater is draining down the slope) is not permitted due to the risk of eaks.

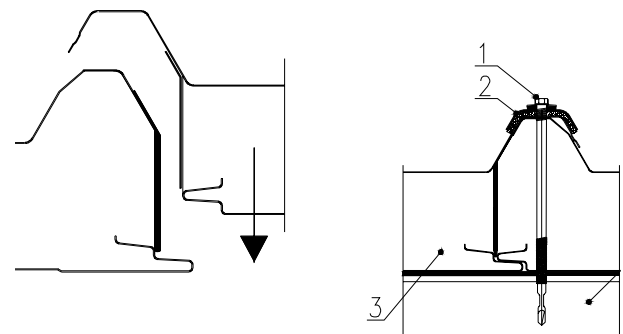

fig. 6

1. Self-drilling fastener with EPDM washer
2. Fastening element L02
3. IzoGold wall sandwich panel
4. Support construction

## 5. Factory applied polyurethane tape

d. Wall panels with a PIR insulation core accommodating the joint with concealed fastener should be fixed to support construction with self-drilling fasteners and fastening element L02 (Fig.7)

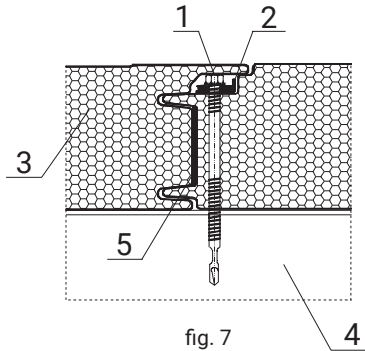

fig. 7

1. Self-drilling fastener with EPDM washer
2. Fastening element L02
3. IzoGold wall sandwich panel
4. Support construction
5. Factory applied polyurethane tape

e. Use power driving tools for the installation of fasteners. Power driving tools should be equipped with a clutch, guide heads and depth limiter

f. Remove any drilling swarf produced during the installation of fasteners immediately to prevent mechanical damage to the coating.

g. Bearing widths of support construction in contact with the sandwich panels should be:

80mm for end lap detail (see Fig.4)

60mm for intermediate supports (see Fig.9)

40mm for end supports (see Fig.9)

h. The distance between the fastener and the edge of the support should not be less than 15mm (Fig.8)

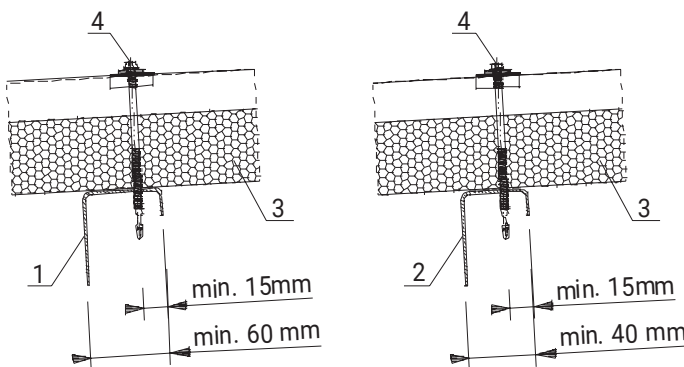

fig. 8

1. Intermediate support
2. End support
3. IzoRoof roof sandwich panel
4. Saddle with a neoprene washer + self-drilling fastener with EPDM washer.

i. As standard, the panels are fixed with two fasteners in general area and three fasteners in areas near the roof edges. The width of corner areas for walls and areas near the roof edges for roofs are given in the national standards for wind loads (fig.9)

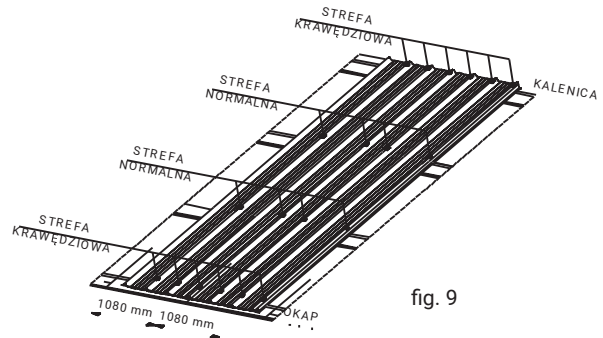

fig. 9

**The final decision with regard to the quantity and fastener distribution belongs to the designer**

j. To avoid thermal bridges in IzoCold coldstore panel joints, resulting from the PIR core shrinkage, any gaps should be filled with polyurethane foam applied on site during assembly (Fig.10).

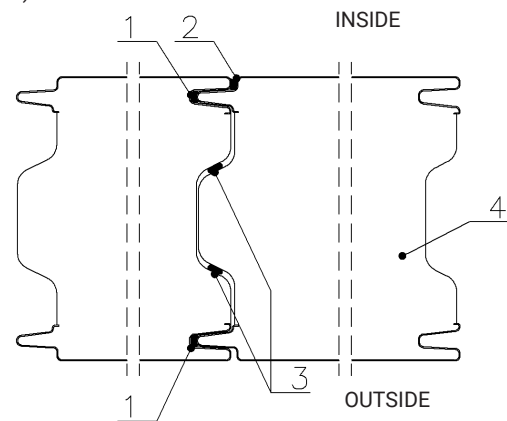

fig. 10

1. Gun grade sealant preventing water vapour and air infiltration into the panel joint.
2. Non-curing, low-modulus sealant applied in the visible panel gap on the internal face.
3. Fill any gaps resulting from the shrinkage of the insulation core with polyurethane foam applied on site.
4. IzoCold PIR/PIR+ coldstore insulated panel.

## 6. Openings in sandwich panels

a. In places where roof or wall sandwich panels are penetrated by services with a diameter of around  $\varnothing 100 \div 250$ mm (smoke vents, ventilation services, etc.) sealing flanges recommended by Izopanel should be used.

b. When roof slopes are designed with rooflights or with large openings, it is necessary to ensure adequate support for the insulated panels around the perimeter of the opening and to seal the areas where openings pass through the roofs.

c. Details of cutting openings and securing them in roof panels should be included in roof panel design and described in an appropriate method statement.

## 7. Method statement for cutting Insulated panels and flashings

a. Use only fine tooth blade jigsaw (reciprocating saw) for cutting insulated panels

b. Cutting panels with angle grinders can void panel guarantee

c. For cutting metal flashings use hand snips only.

d. After cutting, remove any swarf to prevent the risk of mechanical damage occurrence.

e. Any damages to the insulated panel coating and metal flashing coating which occurred during the installation and cutting procedures should be treated with primer paint.

f. External flashings should have a minimum of 150mm overlaps and internal flashings a minimum of 50mm overlaps.