

## TAKING PANEL WITH MWF CORE FROM PACKAGE

### 1. Basic guidelines

- Observe recommendations of the manufacturer – Izopanel Sp. z o.o. – listed in Assembly instructions.
- It is essential to determine assembly weight of a single panel – this can be calculated based on technical data given in Izopanel Technical catalogue.
- When taking a panel please avoid dragging it over the surface of other panels in the package – risk of scratching the cladding
- In panels with MWF core, the internal side is marked with yellow protective foil
- When taking a panel installers always should wear safety gloves.
- Assembly instructions and Technical catalogue can be downloaded at: <http://www.izopanel.pl/dokumentacja>

### 2. Taking panels from package manually – panels with small unit weight.

- Panels with small unit weight can be taken from package and transported to installation site manually. When handling the panels, please, as far as possible, avoid grabbing the upper cladding only, as this can cause detachment of the cladding from the core.

### 3. Taking panels from package manually – panels with medium unit weight.

- As for the presented method of taking the panels from the package, first slightly lift one end of a sandwich panel (min. 2 people) – Figure 1.
- Lift the panel only on a height necessary to drag a textile tie-down strap under the lower surface of the panel to be lifted up. Insert the textile strap under the panel on a depth similar to the value given in Figure 2. Additionally, in the point of the panel suspension on the strap use spacers, e.g. wooden ones, so as to avoid applying point pressure on the panel's side surface when lifting.
- Once textile tie-down straps are placed under the sandwich panel, attach them on a lifting yoke (e.g. made from double-T profile – Figure 3). Pay attention that straps on the lifting yoke are suspended so as to prevent their slipping from the yoke when the panel is being transported to the installation site.

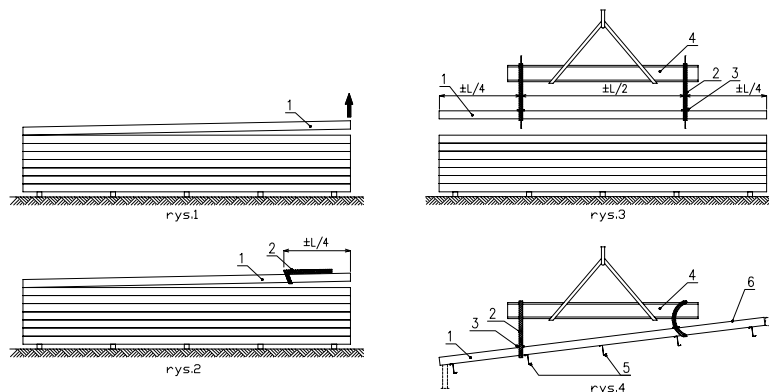

1. Sandwich panel, e.g. IzoRoof MWF  
2. Textile tie-down strap  
3. Spacer

4. Lifting yoke  
5. Roof purlin  
6. Roof slope surface

#### 4. Taking panels from package – panels with large unit weight.

- It is recommended to use specialized vacuum lifting devices for sandwich panels (vacuum lifters). The vacuum force generated by a vacuum pad should not exceed the tensile strength value as declared by the panel manufacturer in the Declaration of Performance.
- To lift sandwich panels with mineral wool core it is recommended to use a double vacuum circulation lifting device.
- A vacuum lifter should have min.:  
4 vacuum pads arranged evenly on the panel being lifted – panels  $L_{max} = 6m$   
8 vacuum pads arranged evenly on the panel being lifted – panels  $L_{max} > 6m$
- **Do not use vacuum lifting device with only one vacuum pad.**
- Please observe all guidelines and recommendations given by the vacuum lifting device's supplier.

